

TOILET PAPER HOLDER

Specify Finish Required →  -B = Bright Stainless Steel  
 -S = Satin #4 Stainless Steel

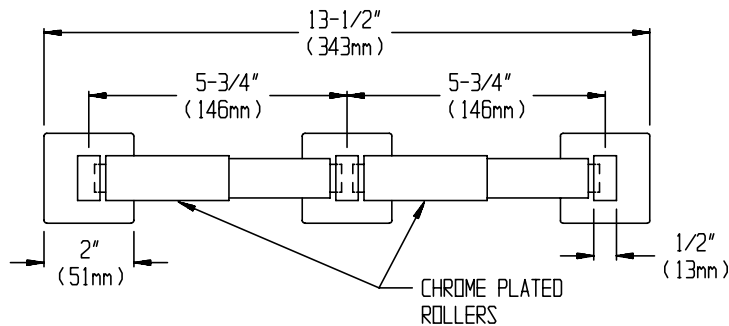

FRONT VIEW

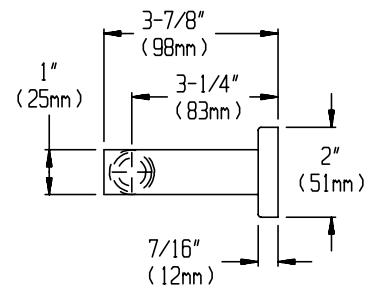

SIDE VIEW

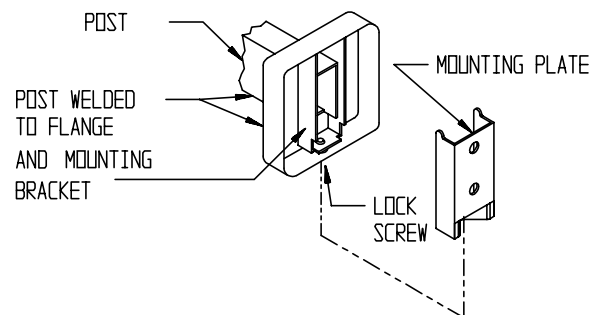

CONCEALED MOUNTING DETAIL

**SPECIFICATION**

Dual Roll Surface Mounted Toilet Paper Holder unit shall hold and dispense two (2) rolls of standard core roll tissue up to 5-1/2" (140mm) diameter. Unit shall be fabricated of stainless steel alloy 18-8, type 304. Posts shall be fabricated of 1/2" x 1" (13mm x 25mm) rectangular tubing. Stainless steel setscrews shall be provided on bottom perimeter of flanges to lock unit to mounting plates. Mounting plates shall be included and shall be 18 gauge. Rollers shall be chrome-plated high-impact resistant ABS plastic and two (2) shall be supplied. All exposed surfaces shall be satin or bright finish as chosen by option and indicated by code suffix.

**INSTALLATION**

Surface mount unit on wall using N° 10 self tapping screws (by others) through holes provided in mounting plates into suitable prepared mountings (by others) or other suitable mounting hardware (by others) to suit wall conditions. Hang post and flange assemblies on mounting plates and tighten setscrews to lock units to plates. For compliance with ICC/ANSI A-117.1-2003 and ADA Accessibility Guidelines, install unit with centerline of roller at 19" (483mm) minimum above finished floor (MIN AFF) to 44" (1118mm) maximum AFF (MAX AFF) and centerline of dispenser no farther than 33" (838mm) from back wall behind commode or between 7" and 9" (178mm to 229mm) from front of commode. Recommended mounting height for general utility is 30" (762mm) AFF to centerline of roll and 14" (356mm) from front of commode to centerline of dispenser.

**OPERATION**

Spring-loaded spindles revolve freely and hold rolls until cores are removed.