

WALL ANCHOR

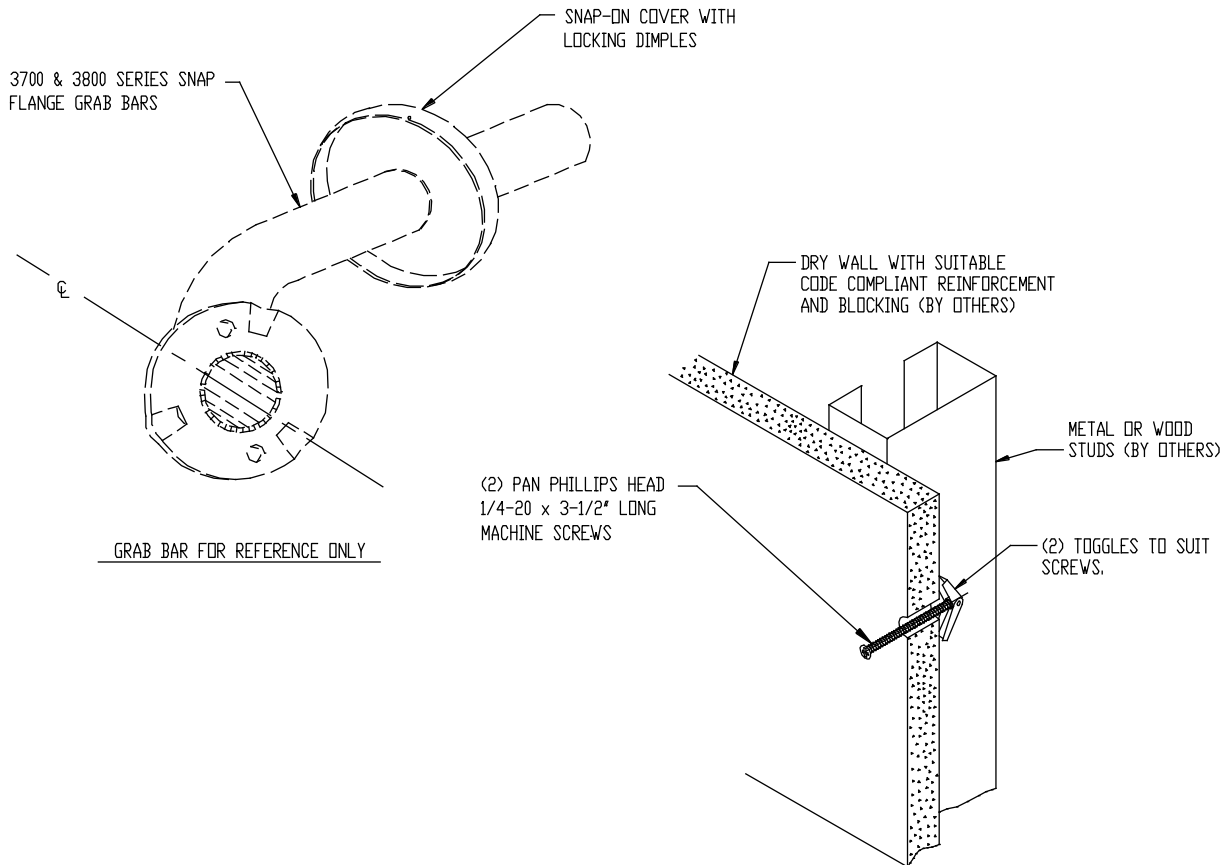

**SPECIFICATION**

Wall Anchor shall be suitable for surface mounting to reinforced dry wall of all grab bars with snap flange mounting (e.g. ASI series 3700 and 3800 grab bars). Wall anchor shall be 1/4-20 x 2" long machine screws with matching toggles. Anchor kit shall contain (2) machine screws with matching toggles. Specify one (1) kit **per flange**.

**INSTALLATION**

For compliance with ADA Accessibility Guidelines mount grab bar so that horizontal centerline is 33" (838mm) minimum to 36" (914mm) maximum above finished floor. Locate grab bar in exact mounting position on wall and mark mounting holes through mounting plate onto wall. Drill 1/2" (13mm) dia. holes into wall and suitable reinforcement. Insert bolts through mounting plate of grab bar and screw on toggles. Insert toggles into drilled holes and tighten until mounting plate is tight against wall. Slide loose cover over mounting flange and snap tight.