

31000 Cubbies Installation Instructions

The flexibility of the wood cubby design allows multiple units to be connected vertically or horizontally with mounting hardware (provided). Before connecting one cubby to a second cubby, or to a base, the appropriate connecting holes in the cubby must be cleared. This is done by pressing a binding post (provided) into each partially pre-drilled hole from the **outside of the cubby towards the inside of the cubby** then removing the **excess material**.

Connecting Cubbies Together

To connect cubbies together, clear the appropriate connecting holes in each cubby. Then connect with binding posts and screws (provided) through the sides and/or tops and bottoms. Fasten units to the wall or floor using appropriate fasteners for the installation (not provided).

Base Assembly (Optional)

After clearing the four holes in the bottom of the cubby, the cubby can be assembled to the base by inserting binding posts through the bottom of the cubby and through the base. Fasten with the provided screws.

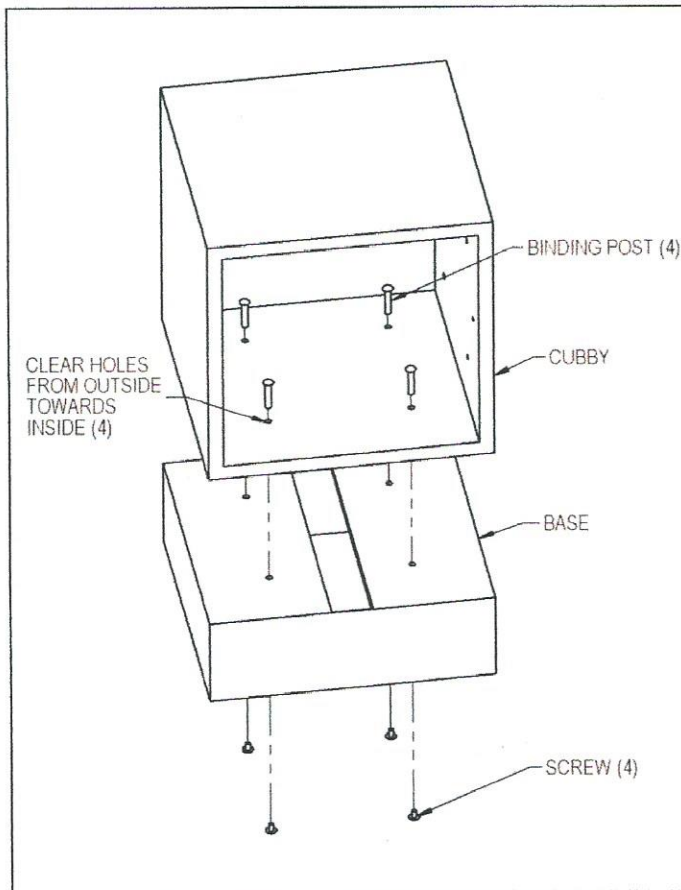

Compartment Shelf Assembly (Optional)

Assemble the compartment shelf by pressing the shelf supports into the provided holes in the cubby. Slide the compartment shelf over the shelf supports aligning the grooves on the sides of the shelf with the supports.

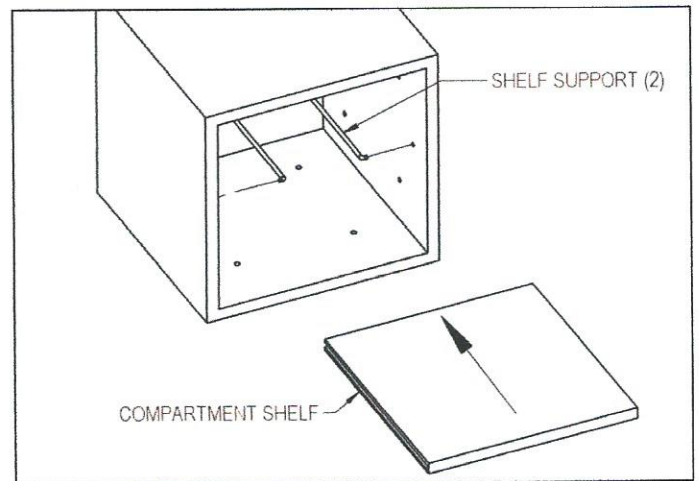

Wall Hook Assembly (Optional)

Install the wall hooks into the pre-drilled holes in the sides of the cubby using the provided hardware.

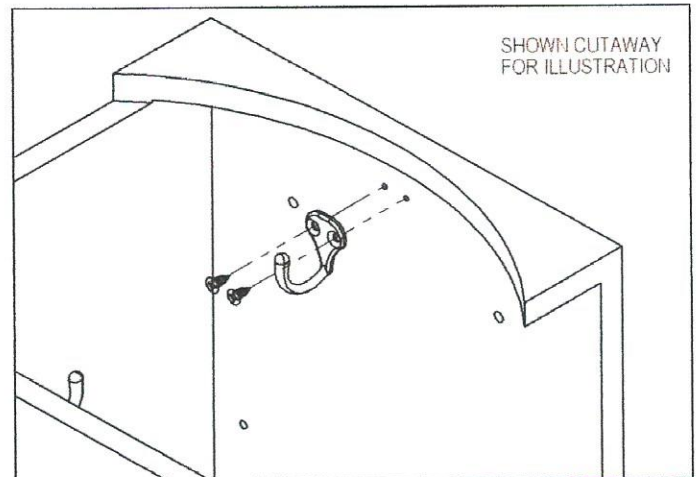

Sample Stacking Installation:

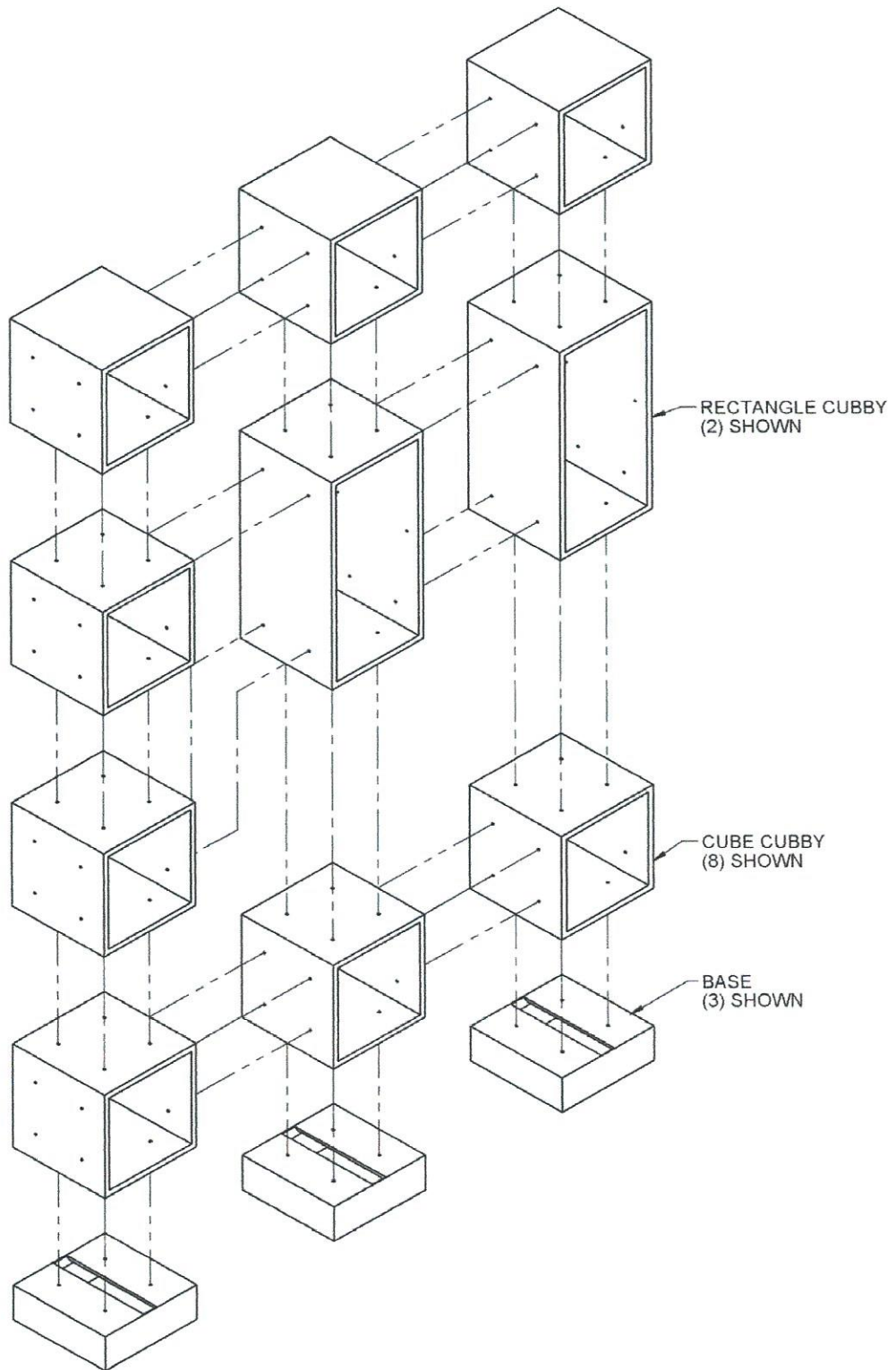

Completed Sample Installation

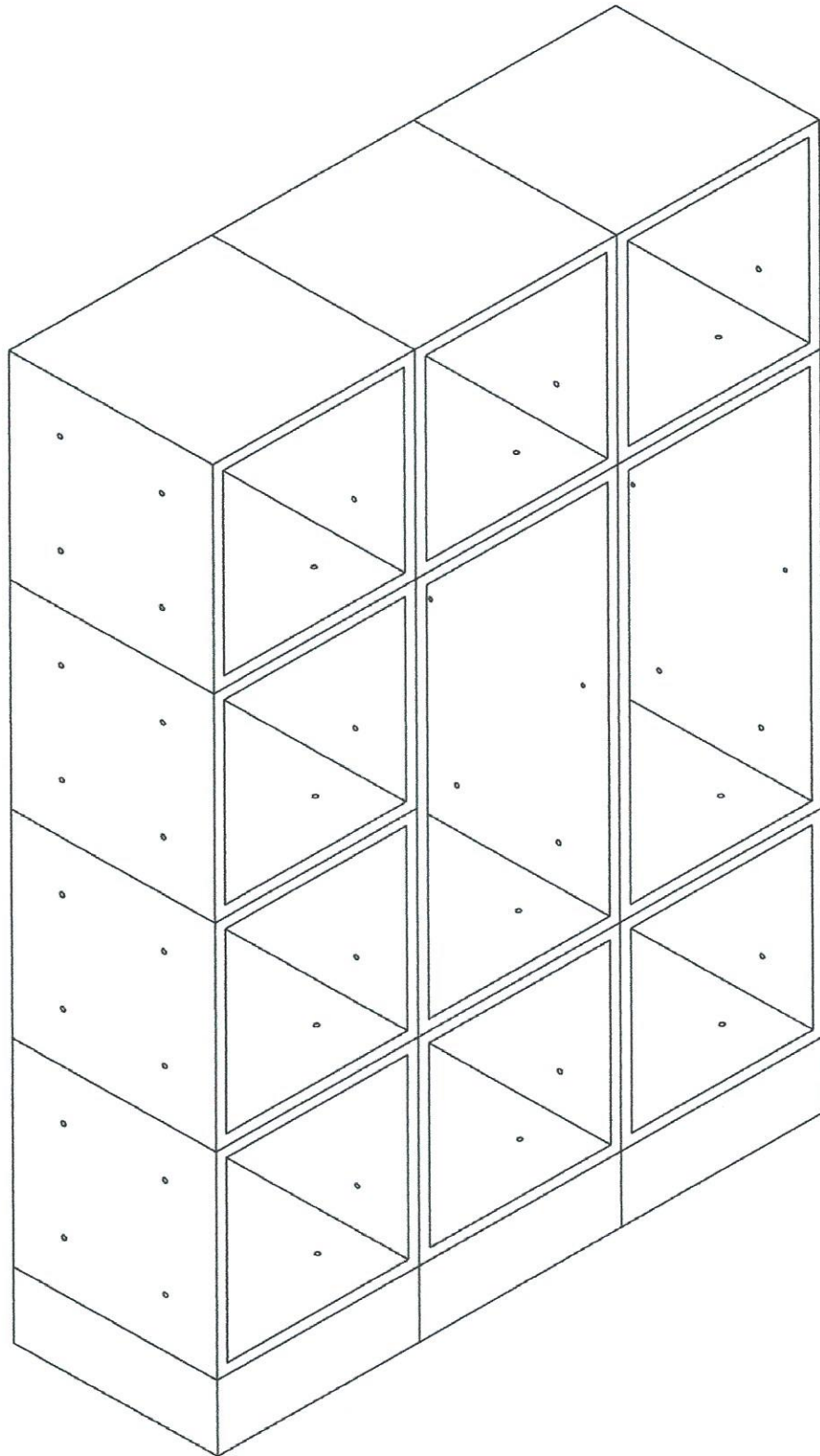

Coat Rod Assembly (Optional)

Installing the coat rod requires drilling two 7/32" diameter holes into each of the left and right cubbies. Drill holes spaced two inches apart and centered side to side within each cubby. Space the holes two inches from the front edge of the cubbies. Next install the coat rod brackets with the provided hardware then slide the coat rod onto the coat rod brackets and attach the coat rod ends. Lastly install #10 self-tapping screws (provided) into the pre-drilled holes in the coat rod to secure the coat rod from sliding.

