

MODEL No: 0185

ISSUED: 10/05

REVISED: 01/10

SURFACE MOUNTED SENSOR HAND DRYER (PG 1/2)

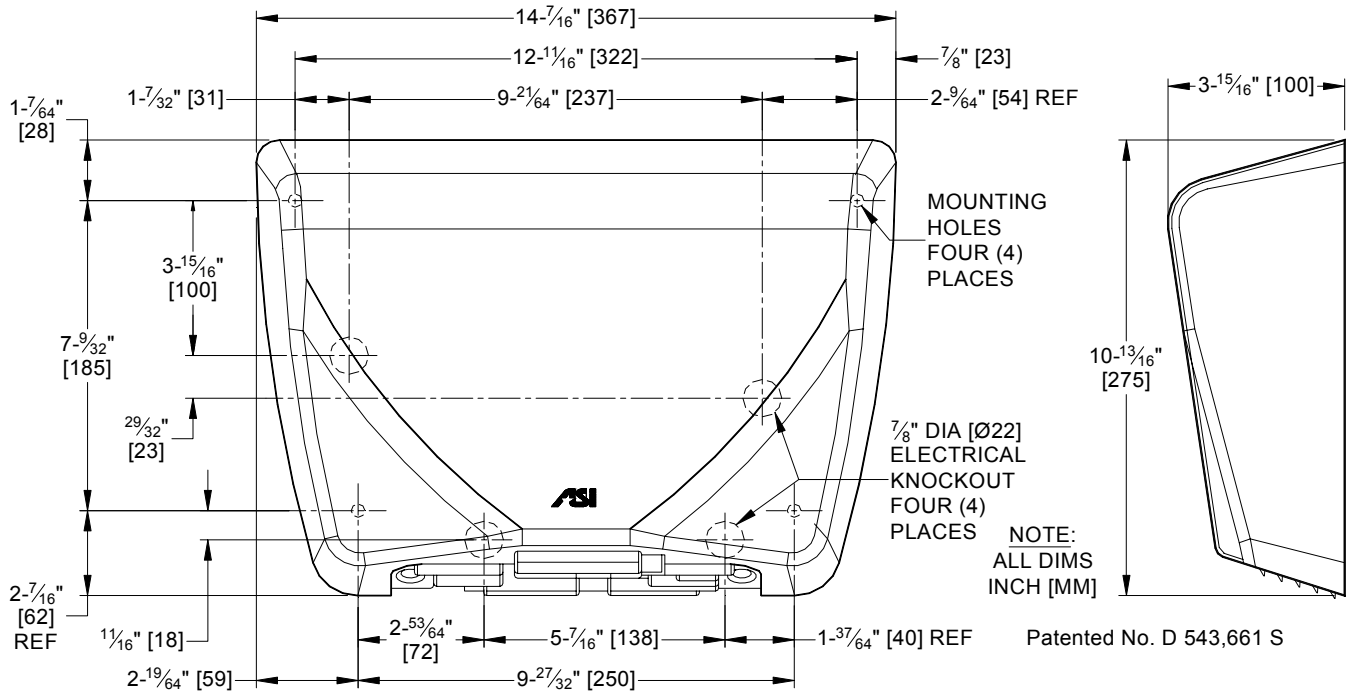

SPECIFICATION

Surface Mounted Hand Dryer shall operate automatically from IR sensor that shall activate dryer when hands are placed in sensor zone. Motor and heating element shall have internal resetting automatic thermal protection. Cover shall be fabricated of one-piece, 16 gauge (.063", {1.6}) thick drawn steel or type 304 stainless steel and shall have all exposed surfaces finished with acid, chip and scratch resistant porcelain enamel on steel or bright or satin finish on stainless steel. Fixed directional air vanes shall be heavy duty, rust proof and tamper resistant. Air intake slots shall not allow access to internal parts. Back plate shall be furnished with vibration isolating mounting bushings. Circuitry shall have self-adjusting time-out and fail-safe off protection controlled by a microprocessor that shall detect and reject false signals and shall automatically self calibrate to provide uniform sensitivity over its entire life span. Entire unit shall be internally electrically grounded. Dryer unit shall have **C** [Ⓢ] **US** approval and be listed under the re-examination services of Underwriters Laboratories, Inc. Unit shall be warranted against defects in materials or workmanship for ten (10) years.

INSTALLATION

Surface mount unit on wall with four (4) 1/4" screws, washers and bushings (supplied) through rubber grommets (supplied) in a corrosion protected formed heavy steel back plate into suitable prepared mountings (by others) or other suitable mounting hardware (by others) to suit wall conditions. For masonry walls use expansion bolts or anchors for 1/4" (6) screws. Electrical service is supplied and connected (by others) prior to installing cover. Cover is secured to back plate with two (2) hex socket security screws (supplied). For compliance with ICC/ANSI A-117.1-2003 and ADA Accessibility Guidelines install unit with bottom of unit 48" (1219) maximum above finished floor (MAX AFF) if clear floor access is provided or 46" (1168) MAX AFF if side reach access over an obstruction (e.g. vanity) with reach depth greater than 10" (254) and less than 25" (635) is only provided or 44" (1118) MAX AFF if forward reach over an obstruction (e.g. commode) with reach depth greater than 20" (508) and less than 25" (635) is only provided. For general utility install unit so that sensor lens is 54" to 56" (1372-1422) AFF. For installation of two or more dryers, dryers should be no closer than 24" (610) on center.

OPERATION

User activates dryer by placing hands under sensor. Dryer automatically shuts off after time-out when user removes hands from sensor zone.

MODEL No: 0185

ISSUED: 10/05

REVISED: 01/10

SURFACE MOUNTED SENSOR HAND DRYER (PG 2/2)

RATINGS

MODEL	TYPE	TIMING	VOLTS HERTZ	AMPS	WATTS	COLOR*
0185	Hand	Automatic	115VAC-50/60Hz	17.6	2022	White
			208VAC-50/60Hz	15.9	1654	
			240VAC-50/60Hz	18.3	2200	

MODEL	MOTOR	H/P	RPM	FAN TYPE	AIR FLOW	HEATING ELEMENT	HEAT TEMP.
0185 115AC	Brush Type Dual Ball Bearings	1/4	7500	Single Inlet Centrifugal	186 CFM (314.5 m ³ /h)	1857 Watt Nichrome wire with auto reset circuit breaker @ 115VAC	149° F (65°) @ 77° F (25°) ambient room temperature
0185 208AC						1519 Watt Nichrome wire with auto reset circuit breaker @ 104VAC	
0185 240AC						2020 Watt Nichrome wire with auto reset circuit breaker @ 240VAC	

COLOR OPTIONS*

Unit is supplied with white finish unless color option is specified. Specify optional color or finish (from chart below) by adding appropriate code number suffix to standard model number (i.e. 0185-93) and indicate option by circle on correct code in chart. For color chips see the **OPTIONS** section.

CODE	COLOR	CODE	COLOR	CODE	COLOR	CODE	COLOR	CODE	COLOR
40	Cool Grey	41	Black	71	Almond	92	Stainless Steel Bright	93	Stainless Steel Satin

Circuit Diagram

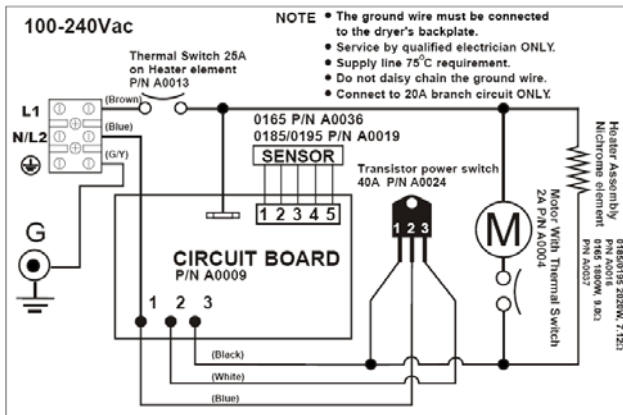

Installation Diagram

