

MODEL №: 64696A

ISSUED: 01/08

REVISED: 03/10

RECESSED AUTOMATIC ROLL PAPER TOWEL DISPENSER AND WASTE RECEPTACLE

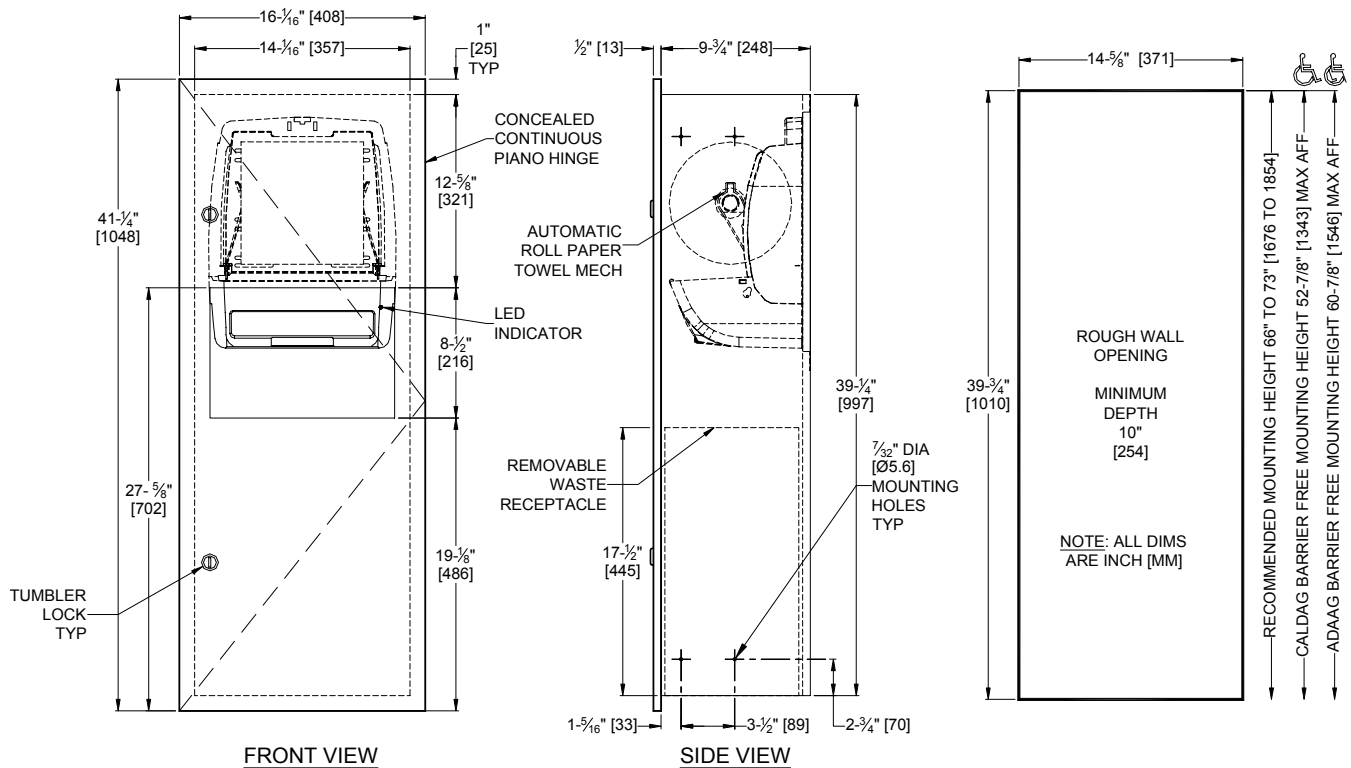

SPECIFICATION

Recessed Automatic Roll Paper Towel Dispenser and Waste Receptacle shall hold and dispense one 8" diameter (Ø203) x 8" wide (203) standard towel roll up to 800 ft. (244m) long and one 8" wide (203) stub roll up to 4" diameter (Ø102) and shall have a waste capacity of 9.4 gallons (36 liters). Automatic Touchless Roll Towel Dispenser shall be powered by four (4) D-size batteries (not supplied) and shall operate automatically to activate towel dispensing when hands are placed in sensor zone. At each activation unit shall feed out a length of towel selected by owner by setting length, delay and paper saver switches. Unit shall have an internal towel cut-off bar. Towel dispensing opening shall have a fully deburred edge for snag free dispensing and user safety. Full-face door, cabinet, dispenser and waste receptacle shall be fabricated of type 304 stainless steel alloy 18-8. All exposed surfaces shall have a satin finish and shall be protected during shipment with PVC film easily removable after installation. Door shall be fabricated of 18 gauge, fabricated from one piece, with no miters, welding or open seams on face and have 1/2" (13) square returns to the wall. Cabinet shall be 20 gauge with a 1" (25.4) wide perimeter trim to lay flush against wall. Unit back plate for mechanism shall be fabricated of same grade 18 gauge. Door shall be attached to the cabinet body with a full length 3/16" diameter (Ø4.8) stainless steel multi-staked piano hinge and shall be held closed with two (2) tumbler locks keyed alike to other ASI washroom equipment. Waste container shall have hemmed edges for safety and a finger grip for easy removal. Structural assembly of all components shall be of welded construction.

INSTALLATION

Install unit in wall recess using № 10 self-tapping screws (by others) through concealed mounting holes provided. Note that top of Rough Wall Opening (RWO) is 3/4" (19) below top of unit. For compliance with ADA Accessibility Guidelines, install unit so that top edge of towel dispenser opening is 48" (1219) maximum above finished floor (MAX AFF).

RWO required is 14-5/8" W x 39-3/4" H x 10" D (371 x 1010 x 254)

OPERATION

Towels are dispensed one length at a time automatically when hands are placed in sensor zone until supply is depleted. Owner predetermines length of towel dispensed by making selections on three (3) three-position switches for length, delay, and economy. Unit may be reloaded with a full roll to automatically start when finished with an existing partial roll and will continue to feed properly when reloaded with a full roll and partial roll is transferred to stub roll position. Refill dispenser by unlocking door and replacing towel roll for an empty or partially empty unit. Dispenser supply is replenished, batteries are replaced and waste receptacle is emptied manually on cycles determined by maintenance needs. LED indicates sensing and battery condition. Locking full-face door over compartments prevents unauthorized access or removal.