

MODEL No: 0350

ISSUED: 1-87

REVISED: 9-96

SURGICAL TYPE LIQUID SOAP DISPENSER

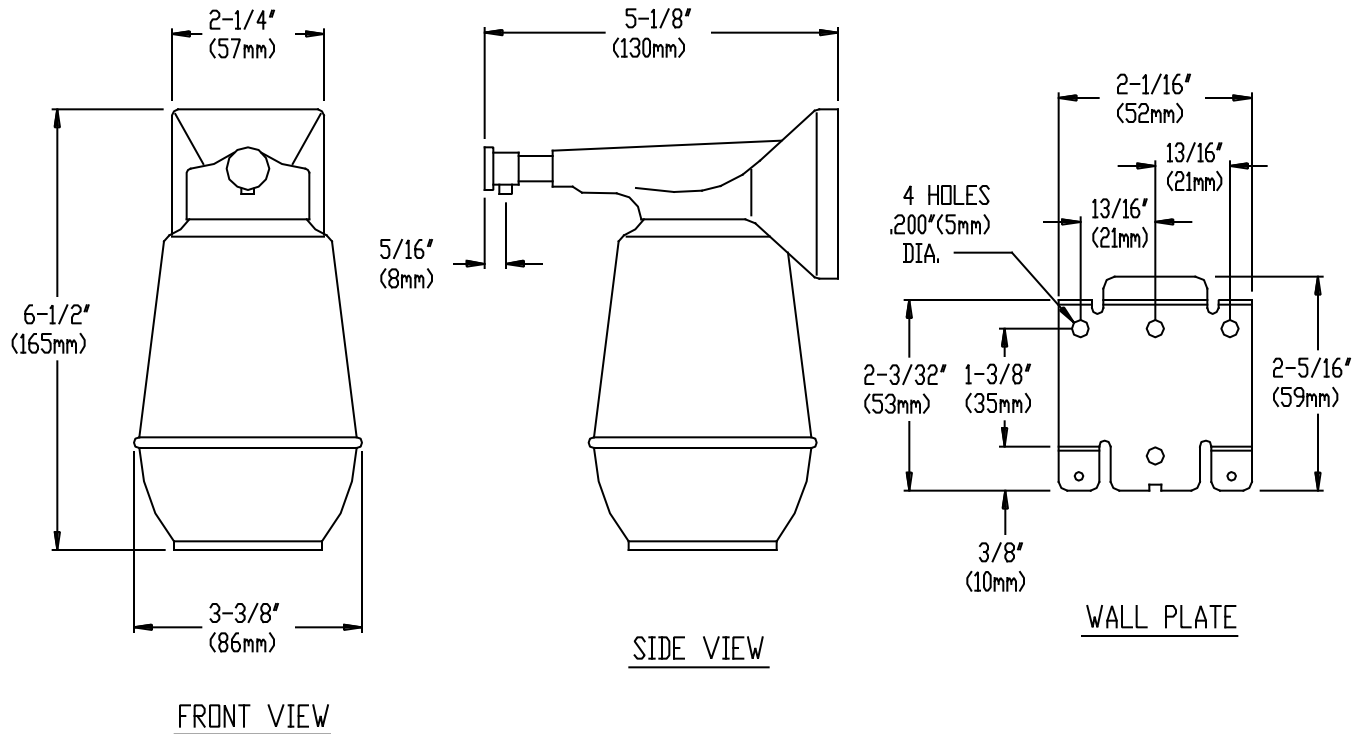

SPECIFICATION

Surface Mounted Surgical Type Liquid Soap Dispenser shall dispense 16 oz (.47 liters) of soap or antiseptic solution. Dispenser/ Valve unit shall be constructed of chrome-plated brass body with stainless steel and plastic internal parts. Valve operation shall comply with ADA Accessibility Guidelines by requiring no more than 5 lbs_f (22.2 Newtons) pressure to actuate and require no grasping or twisting by operator. Soap "globe" shall be fabricated of white polyethylene.

INSTALLATION

Unit is secured to a wall plate which is surface mounted to wall or partition using N^o10 self tapping screws (supplied). For maximum usability and compliance with ADA Accessibility Guidelines, unit should be installed so that valve is 54" (1371mm) maximum above finished floor (AFF) when clear side access is provided; 48" (1219mm) AFF. with forward reach access only and 46" (1168mm) with side reach over an obstruction (ie: vanity). Recommended installation is 42" (1066mm) AFF or 6" (152mm) minimum above wash basin.

OPERATION

Soap is manually dispensed by depressing push button. Unit is reloaded by unlocking soap tank from wall bracket. Soap will continue to feed properly until empty. Tank supply is replenished manually on cycle determined by maintenance needs.