

MODEL No: 046921

ISSUED: 1-87

REVISED: 4-07

RECESSED ROLL PAPER TOWEL DISPENSER AND WASTE RECEPTACLE

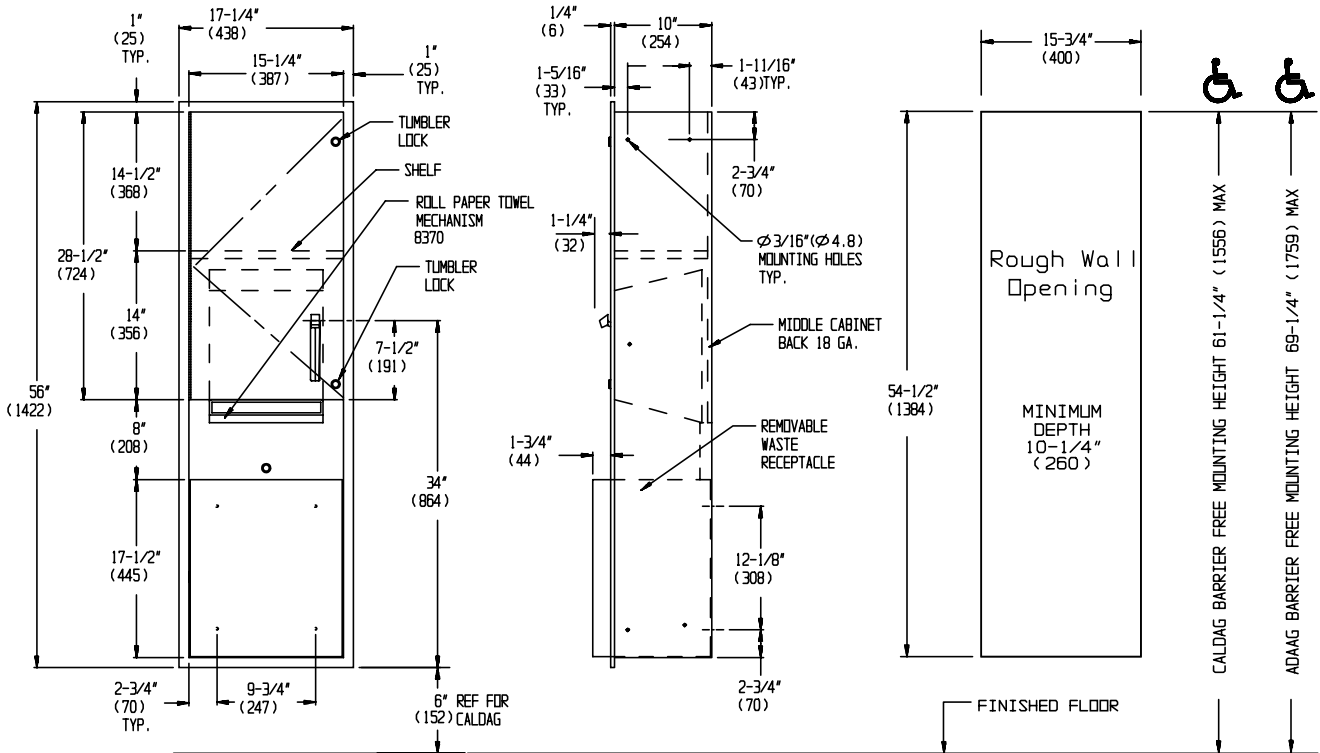

Note:
Dimensions are in inches
and (millimeters)

SPECIFICATION

Recessed Roll Paper Towel Dispenser and Waste Receptacle shall hold and dispense one 8" diameter (Ø203) x 8" or 9" (203/229) wide standard towel roll up to 800 feet (244m) long and one stub roll up to 4" diameter (Ø102) and shall have a waste capacity of 13.3 gallons (50.4 liters). A lever operated dispensing mechanism shall be supplied. Cabinet, frame and waste container shall be fabricated of 22 gauge type 304 stainless steel alloy 18-8. Towel dispenser door and unit back plate for mechanism shall be fabricated of same grade 18 gauge. All exposed surfaces shall have N^o 4 satin finish protected by PVC film easily removed after installation. Towel dispensing slot shall be smooth and burr-free for snag-free dispensing and user safety. Door shall be attached to cabinet at side with a full-length 3/16" diameter (Ø4.8) stainless steel multi-staked piano hinge and be held closed with two (2) tumbler locks keyed alike to other ASI washroom equipment. Internal cabinet shelf shall be suitable for storage of replacement towel rolls or other janitorial items. Waste container shall have hemmed edges for safety and shall be retained by a tumbler lock keyed alike to other ASI washroom equipment. Face trim shall be 1" (25.4) wide formed from one piece with no miters, welding or open seams and have 1/4" (6.4) square returns to wall. Structural assembly of all components shall be of welded construction.

INSTALLATION

Install unit in wall recess using N^o 10 self-tapping screws (by others) through concealed mounting holes provided. Note that top of Rough Wall Opening (RWO) is 3/4" (19) below top of unit. For compliance with ADA Accessibility Guidelines, install unit so that towel dispenser lever is 48" (1219) maximum above finished floor (MAX AFF).

RWO required is 15-3/4" W x 54-1/2" H x 10-1/4" D minimum (400 x 1384 x 260)

OPERATION

Towels are fed by lever action until supply is depleted. Towel feed length is adjustable for economy by pin (supplied) limiting of lever stroke length. Unit may be reloaded with a full roll to automatically start when finished with an existing partial roll. Waste receptacle is emptied on a cycle determined by maintenance needs. Locking compartment and receptacle retainer prevents unauthorized access or removal.